



Embassy The Sure Defence

The image features a detailed architectural rendering of a secure embassy building, presented as a cutaway view of a 3D model. The building is situated on a site plan that includes various rooms and corridors, with labels such as 'CLUB', 'RECEPTION', 'OFFICE', and 'CONFERENCE ROOM'. The rendering shows the building's exterior walls, windows, and internal structure, including a central courtyard area. The overall design is modern and functional, emphasizing security and safety. The background is a grayscale architectural drawing of the building's footprint and surrounding site plan, providing context for the 3D model.





# SAFE ROOMS | PANIC ROOMS SECURE ROOMS & VAULTS

AT HOME, AT WORK, AND IN LEISURE



EMBASSY MODULAR STEEL SECURITY WALLING

THE SURE DEFENCE

# PROTECT YOUR FAMILY AND VALUED POSSESSIONS

WITH AN EMBASSY SAFE / PANIC ROOM.

With over 30 years' experience providing high security physical protection products, Burton Security can provide the best solutions to protect your family and most valuable possessions. Working with you allows us to design the highest level of bespoke safe rooms and vaults for your family to take lifesaving shelter during a robbery, burglary, home invasion or terrorist attack.

## EMBASSY MODULAR STEEL SECURITY

*Walling*



A safe room, or panic room as they are often called, provides a safe hiding place for your loved ones until your security team or the emergency services can be contacted.

Coordinating directly with your interior designer and architect ensures that we identify the protection level required to create safe rooms that are attack resistant, bullet proof, functional, safe and aesthetically pleasing.

We have a choice of security rooms and walling levels to protect against physical attack tools and ballistic weapons, such as pistols, handguns, and rifles. Additionally, our range of luxury armoured and sliding doors can be hidden from view, something that can be specified during the design process.

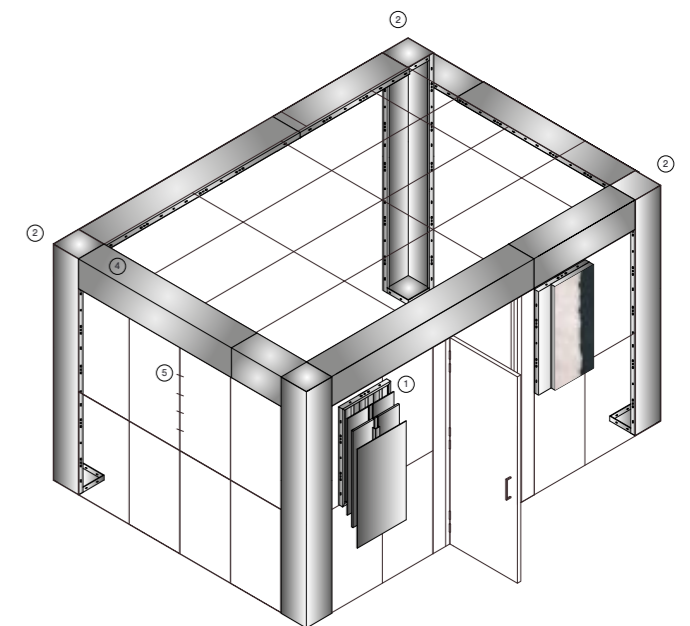



# PRIVATE RESIDENCES, LUXURY APARTMENTS, YACHTS AND OFFICES



An Embassy safe / panic room or a vault can be built as a stand-alone room or we can discreetly convert existing areas of the home, such as bedrooms, walk in wardrobes, guest rooms, ensembles, living rooms, offices, and garages to keep your family and valuables safe from intruders.

Embassy panic rooms are ideal for high-net-worth individuals, dignitaries, and celebrities wanting to avoid life and death situations and protect the family in setting such as private residences, home offices, holiday homes, luxury apartments, and super yachts.

Our designs include adjoining rooms to create a central places of safety for the family with hidden armoured doors, manual or powered sliding doors, access control and window protection such as shutters, bar sets and bulletproof glass for the highest level of protection.

For larger ground floor installations designed to protect collections, art, classic cars, jewellery, precious metals, cash, and important documents we also have a range of strongrooms and vaults made from heavier steel and composite constructions.

## High Security Doors

Armoured security doors at the property boundaries can provide an additional layer of protection and time critical safety so you can reach your panic room in safety!

## Embassy Design

Enables architects and specifiers to embed secure design from the outset, creating the perfect balance of security and luxurious interior design.

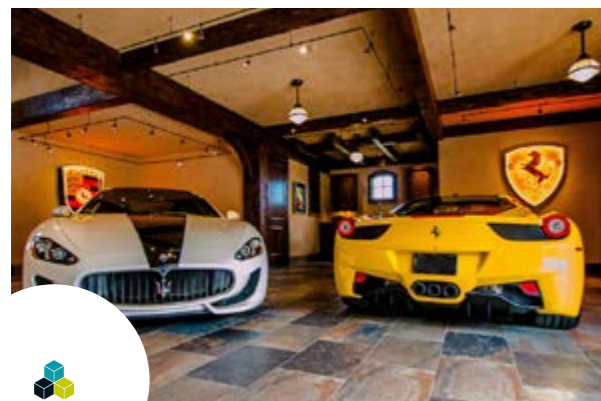

Embassy modular security steel walling and rooms installed for maximum protection worldwide.

# EMBASSIES, HOTELS AND SCHOOLS

In a world where the threat of terrorist attacks has become more common on Government embassies, hotels, retail areas, and sadly in schools too, the protection of personnel within safe areas of retreat has become more important to our way of living and is rightly now the everyday duty of care for many.

Our Embassy modular steel security walling is ideal for designing bespoke rooms or converting existing rooms to offer a high level of physical attack protection, ballistic resistant walling protection combined with bulletproof door sets creating the safe room required.

In these environments a well drilled emergency plan incorporating a designated, professionally designed safe room can save lives and help reduce the risk of robbery and hostage situations.

Working with your architects and designers each Embassy walling or safe room installation can be decorated discreetly to match its natural surroundings and create a hidden room or become part of a luxurious experience for clients, guests, visitors, pupils or staff.

## Physical Security

**Provides time delay. Delay equals safety and time to notify the Police authorities!**



## High Security Armoured Doors

We provide a large range of security door sets including traditionally hinged, luxury, and bespoke sliding door models!

## Escape Rooms

An Embassy safe room is an ideal place of retreat and safety if under attack during a robbery, aggravated burglary or assault!



# ARTS & LEISURE

It has been estimated by U.S. News that more than 50,000 pieces of artwork are stolen globally each year, and that 40% of these crimes are committed in the UK. In addition to the billions of pounds worth of loss attributed to these thefts, storage vault fires have accounted for many millions more. The risk to art, film and musical history has almost never been greater as general concerns surrounding worldwide security matters continue to grow, and as the threats from terrorism and armed robbery also remain high.

Our bespoke Embassy modular steel security walling, strongrooms, portable security rooms and vault systems are ideal for designing both fixed and temporary solutions to these threats. Suitable too for the conversion of existing rooms within buildings, vehicles, and yachts, Embassy offers a high level of physical attack protection, fire protection and ballistic resistance.

Whatever your requirements, choose Embassy security rooms and doors to create the ultimate protection against burglary, robbery, fire and armed assault.



## Jewels and Precious Metals

- Regalia
- Crowns
- Rings
- Diamonds, Sapphires, Emeralds, Rubies, Pearls,
- Opel's
- Gold, Silver, Platinum and Palladium
- Collections
- Watches

## The Seven Seas

- Luxury Yachts
- Superyachts
- Boats
- Ships
- Marinas
- Maritime

## Art & Literature

- Museums
- Galleries
- Art
- History
- Science
- Plant, animal, fossil, rock and mineral
- Architectural
- Design, fashion and textiles
- Libraries
- Maritime
- Transport
- Modern Art
- Auction Houses
- Religious Artifacts
- Exhibitions
- Private Collections
- Vaults

## Music & Film

- Music Studios
- Master Recordings
- Multitrack Tapes
- Sound Laboratories
- Memorabilia
- Film Reels
- Music and Film Collections
- Instrument and History
- Collectors

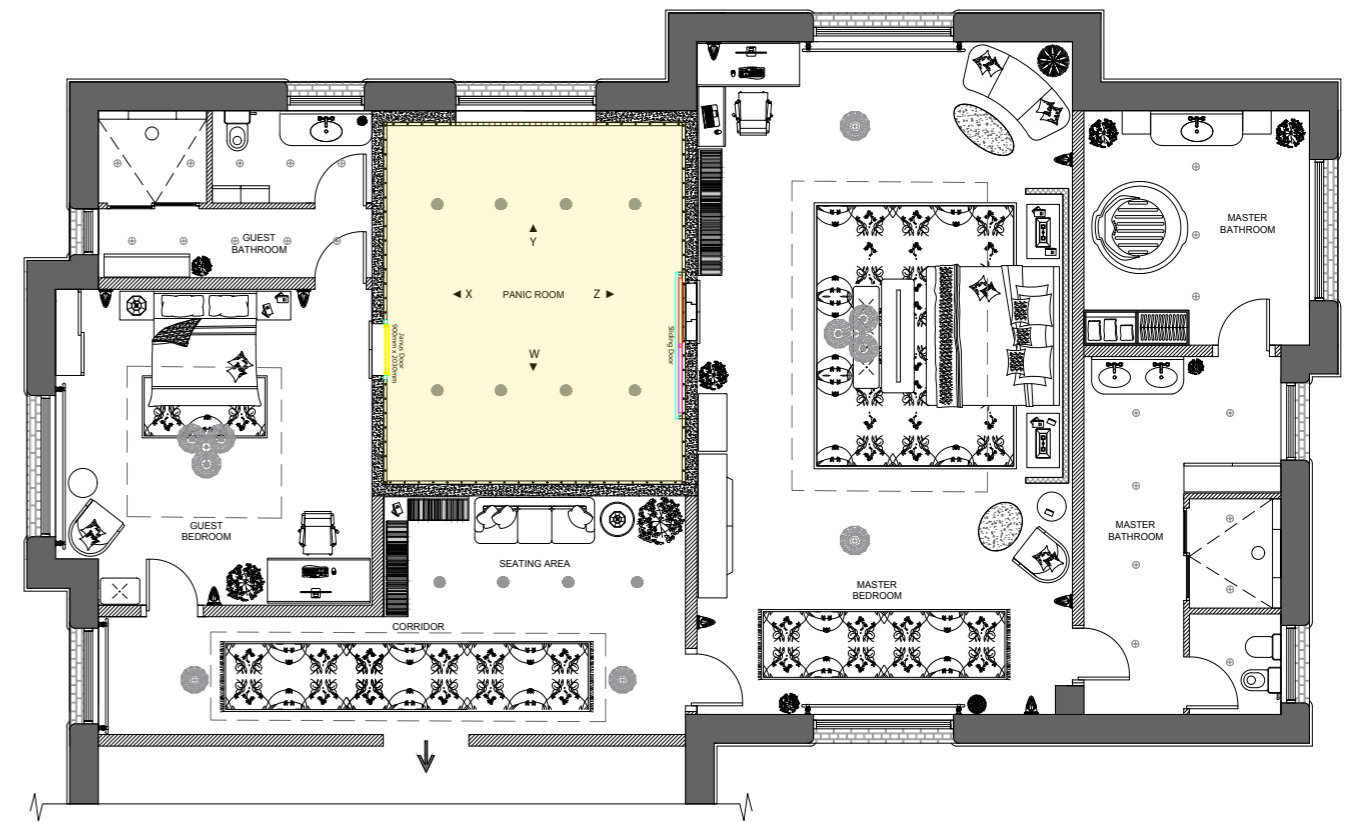

# ARCHITECTS, DESIGNERS & CONTRUCTION

Embassy modular steel security walling and our high security luxurious safes are ideal for designing bespoke rooms or converting existing rooms, offering a high level of physical attack protection, ballistic resistant walling protection combined with bulletproof door sets creating the safe room required.

We carefully listen to our clients so we can fully understand their security needs, concerns and lifestyle. With a collaborative approach with our clients, their designers and architects we work to exceed expectations in all that we deliver with that personal touch which makes us unique in our approach.

Following on from your preliminary discussion to assess your security needs, now your attention can turn to the finer details to ensure your chosen safe room compliments your lifestyle. Working with your designers we can combine innovative high security solutions with architecture and interior design to create wonderful living spaces to fit in with your lifestyle, bringing everything together to create a beautiful home.

Embassy is manufactured in the United Kingdom through design, innovation and investment in British engineering. We look forward to discussing your luxury bespoke requirements with our professional team as

part of our fully comprehensive consultation. Offering our customers not only unique, bespoke safe and panic rooms but a complete range of products for your home and business that will protect your most valuable possessions.

Working with your professionals drawn from architecture, interior design, construction and project management fields we can provide an exclusive range of exquisite safes using the finest materials. All hand finished using the best British craftsmanship to give the safe your personal touch.

*Ultimate Privacy*

We offer peace of mind that your security project will be discreetly designed, managed and installed by our expert UK team.

Our team will ensure that everything is taken care of, from design to install we give you complete transparency and privacy.

*Trusted*

Product quality, trust, honesty, reliability and professionalism provided as standard throughout the whole journey

*Expertise*

We have a wealth of expertise in-house that sets our services apart in the world of personal and valuables protection in a luxury setting





# RETAIL AND COMMERCIAL



From the world's most advanced safe deposit centres in Hong Kong, to securing cash, bullion and valuables in banks and retailers across Europe and the Middle East; the team at Burton Security have the experience to advise, design, and deliver physical security solutions to protect you, your staff and your assets.

Embassy modular steel security walling, vaults and high security doors are ideal for designing bespoke rooms or converting existing rooms to offer a high level of physical attack protection, ballistic resistance, and controlled access or fire escape.

Our security solutions and safes can be found in most high street stores, superstores, banks, safe deposit centres, and protecting high street ATM's.

Unfortunately, the current cost of living crisis has seen a huge increase in theft from supermarkets. Working with heads of security we have designed anti-theft solutions to protect the stored cash within self-checkout machines, safely prevent snatch theft shoplifting via fire escapes, supply trolleys to aid the safe transit of cash through busy stores, and the ever-important service and daily management of all types of onsite security assets.

With a burgeoning reputation for providing turnkey solutions Burton Security are the perfect partner for anyone considering investing in the security of safe deposit centres, sanctuary rooms for high-net-worth individuals, cash handling areas, retail stores, bookmakers, banks, and home security too.

## Jewellers & High Street Stores

**An Embassy safe room is an ideal place of retreat and safety if under attack during an aggravated burglary!**



# ARMORIES, FIRING RANGES & GUN COLLECTIONS

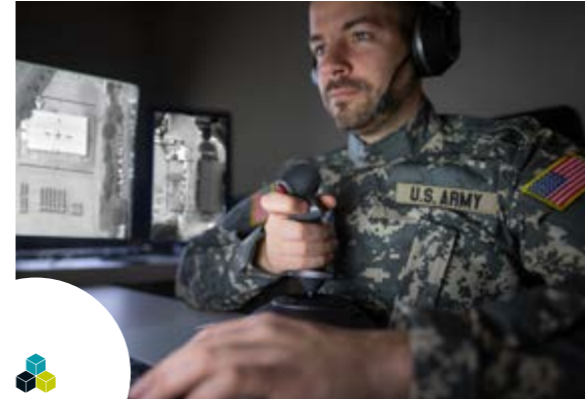

## MILITARY

Armouries  
Shooting Ranges  
Gun Clubs  
Gun Collections  
Antiques

## BALLISTIC RATINGS

Tested and certified  
Bullet-resistant  
performance features  
FB1 – FB7 can be combined  
with burglary resistance  
performance levels 1 – 8.

## TECH TALK

1001.01 is a technical document that specifies the performance requirements that equipment should meet to satisfy the needs of certification and procurement bodies as well as the individual user.

We have a large range of bespoke and off the shelf solutions developed for storing guns, protecting personnel in armouries, at shooting ranges, and which provide physical security protection when threatened with a firearm.

Our modular layered approach to designing and manufacturing Embassy walling means we can apply levels of materials that are fully tested and certified to BR1 to BR7, EN1522 FSG, and EN1523 FSG standards for ballistic resistant protection.

Personnel protection for the inside of gun rooms, safe room or areas used for firing weapons can be lined with our coatings developed and fully tested at Precision Ballistics Laboratories to test procedure 1001.01 for Anti-Spall and Anti-Ricochet properties.

Embassy modular steel security walling is ideal for designing a layered approach for building secure rooms and portable rooms that can include physical security, ballistic protection and anti-ricochet protection.



For smaller or additional secure gun storage and gun collection displays we have a full range of Sold Secure tested, police preferred gun safes and high security luxury glass display safes.

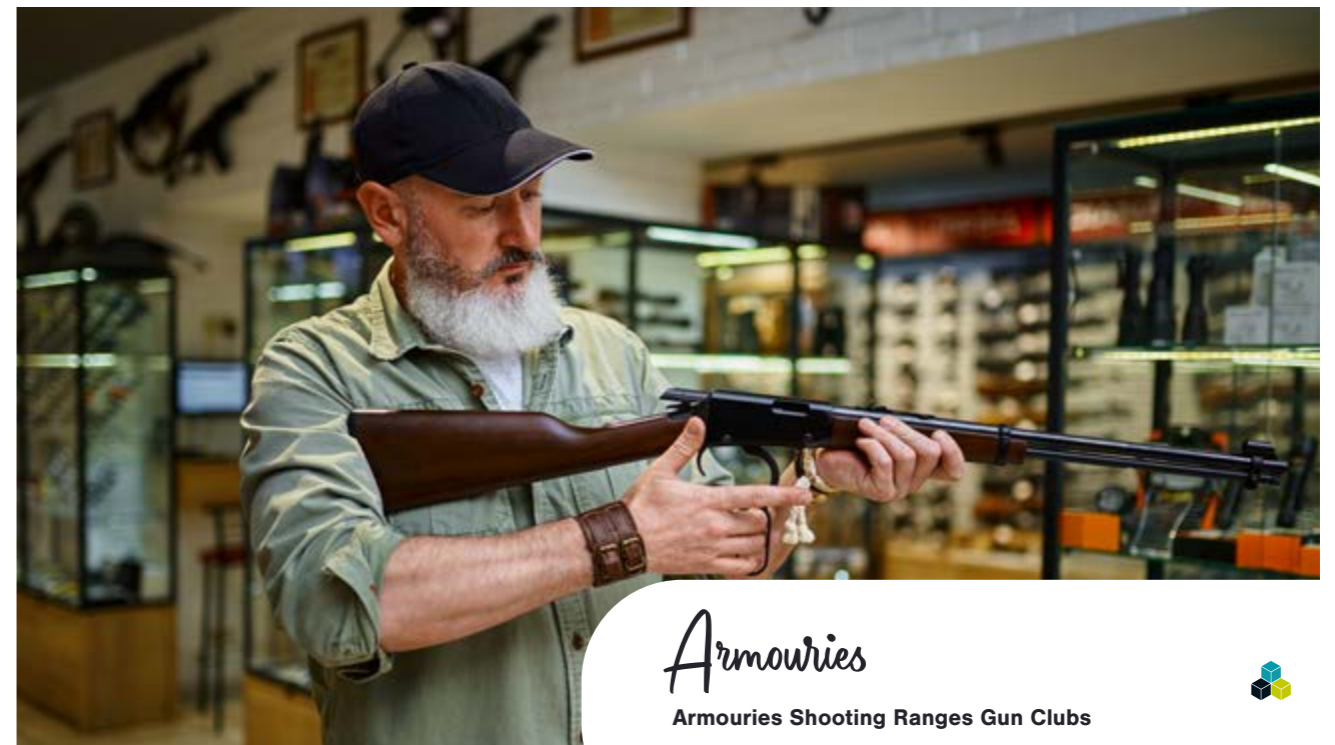

*Armouries*

Armouries Shooting Ranges Gun Clubs



Embassy Code	Security Walling Details	Security Level	Certified Security	Certified Ballistic	Attack Threat Protection	Panel Thickness mm	Weight p/m2	
<b>E1</b>	Single layer steel fabrication wall panel	1	*	-	Low technology level of attack using small, very easily concealed tools.	50mm	22 kg	
<b>E2</b>	Single layer steel fabrication wall panel with additional steel bracing	2	*	-	More determined attack using easily concealed tools of a greater mechanical advantage.	50mm	26 kg	
<b>E3</b>	Single layer steel fabrication wall panel with higher level additional steel bracing	3	*	-	Deliberate forced entry using a wide selection of commonly available, relatively easily concealed tools.	50mm	51 kg	
<b>E4</b>	Multi layered steel fabrication wall panel with higher level additional steel bracing	4	*	-	Experienced attempts at forced entry and threat to life.	50mm	80 kg	
<b>E4 EB4</b>	Multi layered steel fabrication wall panel with higher level additional steel bracing and ultra hardened ballistic steel	4 + 4B	*	FB4	Experienced attempts at forced entry and threat to life, Including the use of ballistic weapons.	53mm	82 kg	
<b>E5</b>	Heavy duty multi layered steel fabrication wall panel with higher level additional steel bracing	5	*	-	Experienced attempts at forced entry using tools of a greater battery power.	54mm	88 kg	
<b>E6</b>	Heavier duty multi layered steel and composite panel fabrication wall panel with higher level hardened additional steel bracing	6	*	-	Professional attempts at forced entry into higher value storage areas and threat to life.	54mm	100 kg	
<b>E6 EB6</b>	Heavier duty multi layered steel and composite panel fabrication wall panel with higher level hardened additional steel bracing and ultra hardened thicker ballistic steel	6 + 6B	*	FB6	Professional attempts at forced entry into higher value storage areas and threat to life, Including the use of ballistic weapons.	56mm	121 kg	
<b>O6</b>	High security strongroom modular walling manufactured of steel construction with anti-cut brace bars and a re-enforced concrete composite suitable for heavy duty vault doors. Certified by LPCB and ECB.S	**	6V	LPS1175 F10 (SR6) and G5 EN1143-1Grade 2	-	Professional attempts at forced entry into higher value storage areas and threat to life.	27mm	90 kg
<b>C7</b>	Higher level of thicker vault walling manufactured of heavy steel construction with anti-cut brace bars, barrier materials and dense re-enforced concrete composite suitable for heavy duty vault doors	***	7	EN1143-1Grade 4	-	Enhanced professional attempts of access to high value assets.	70mm	210 kg
<b>C8</b>	Higher level of thicker vault walling including EX protection against explosives, manufactured of heavy steel construction with anti-cut brace bars, barrier materials and dense re-enforced concrete composite suitable for heavy duty vault doors. Certified by ECB.S	***	8	EN1143-1Grade 6	-	Extreme methods of access to very high value assets using portable tools.	70mm	225 kg
<b>Optional Wall Linings</b>								
<b>EB4</b>	Advanced hardened steel protection plates with guaranteed ballistic properties	4B	-	FB4	Attckers with Rifles, automatic pistols and hand guns	3mm	25 kg	
<b>EB6</b>	Advanced hardened steel protection plates with higher levels of guaranteed ballistic properties	6B	-	FB6	Attackers Rifles, automatic pistols, hand guns, assault rifles and rifles FMJ (full metal jacket)	6mm	52 kg	
<b>EAR</b>	Anti-Ricochet and anti-Spall Ballistic lining and panelling	AR	-	PBL1001.01	Attackers and misfiring of weapons -Tested in accordance with PBL1001.0 Standard test method against the following threats 62g Fed Tac Bon, 5.56x45mm SS109, 9mm 124grn TMJ, .38s&pc 158grn JSP and 7.62 150grn Steel FMJ	30mm	4.5 kg	
<b>RWA45</b>	Rockwool high quality, high density resin bonded slabs	Insulation	EN 13162 Euroclass A1	-	Thermal, acoustic and fire resistant insulation	25-100mm	1 kg	

\* Non certified

\*\*Manufactured in the EU and certified in the UK to LPS 1175 Issue 8 F10 SR6 and G5 by LPCB - Built to a Police Preferred Specification - Secured By Design



\*\*\*Manufactured in the EU and certified to EN1143-1 G4 and EN1143-1 G6 by ECB.S - Built to a Police Preferred Specification - Secured By Design



**EXAMPLE EMBASSY MODULAR ROOM**

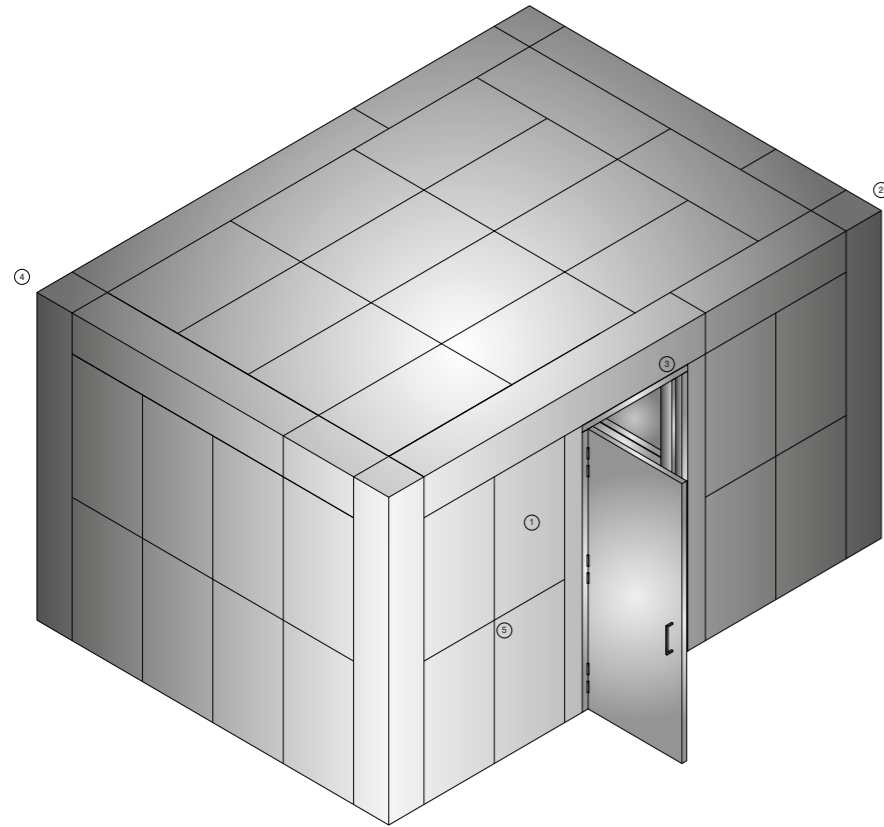

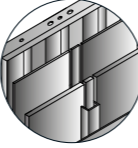
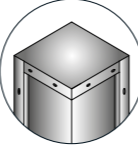
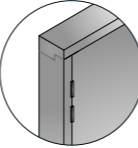
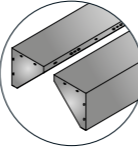
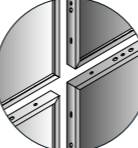
- ① Panel Section 
- ② Corner Panel 
- ③ Door Frame 
- ④ Top Edge Panel 
- ⑤ Modular Fixing 

**EXAMPLE EMBASSY MODULAR WALLING AND DOORS**

Layered construction providing maximum security

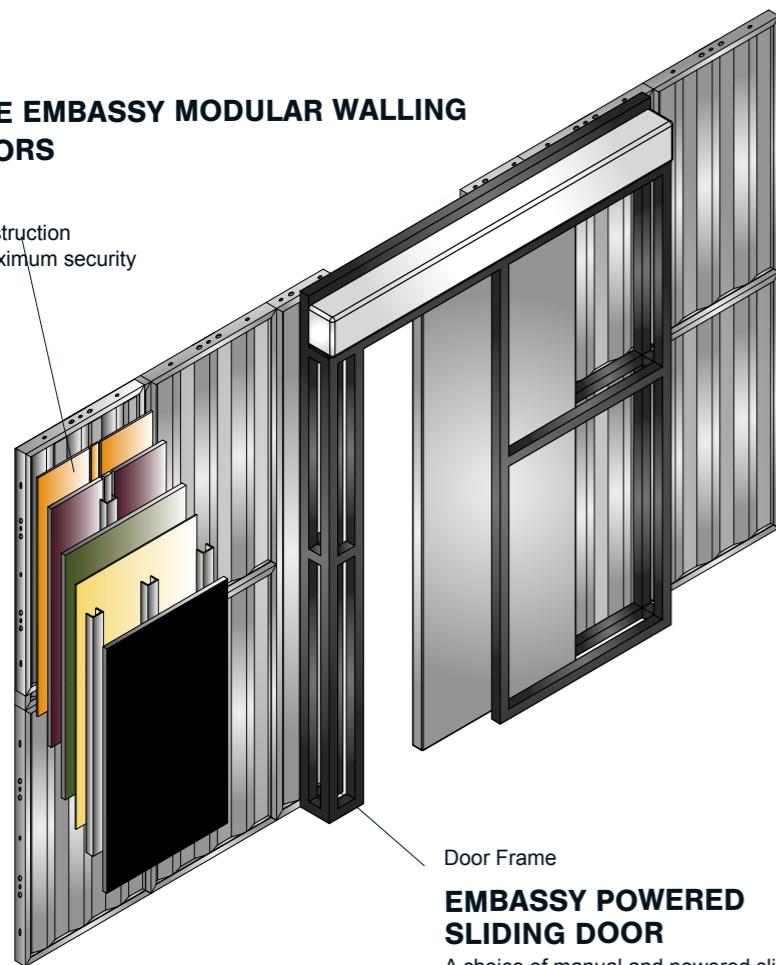

Door Frame

**EMBASSY POWERED SLIDING DOOR**

A choice of manual and powered sliding doors protected by Embassy walling



**EMBASSY DOOR SET**

Normally hinged bespoke security door set

**EMBASSY MODULAR STEEL SECURITY WALLING**



E1



E2

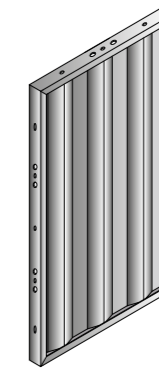

E3

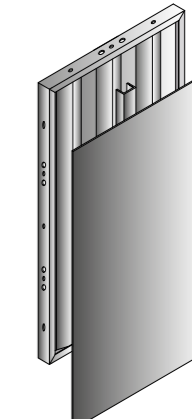

E4

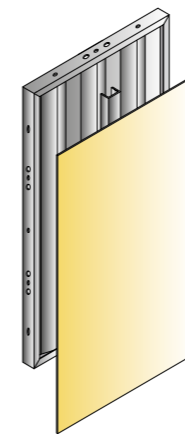

E4 EB4

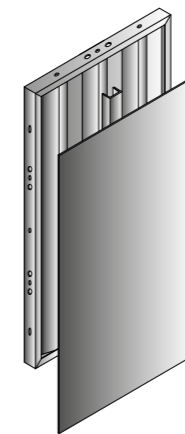

E5

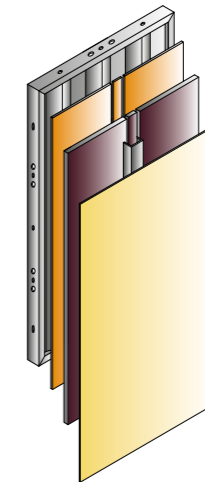

E6

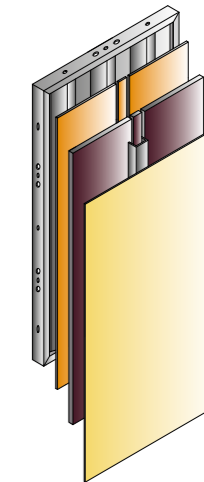

E6 EB6

**Optional Modular Security Panels**



EB4



EB6



EAR

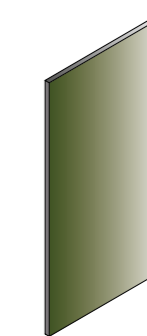

RWA45



# SECTORS WE SERVE



**EMBASSY  
MODULAR  
ROOM**



- Critical National infrastructure
- Data Centres
- Nuclear & Utilities
- Petrochemical
- .....
- Retail
- Warehousing
- Kiosk
- .....
- Utilities
- Gas
- Electricity
- Water
- Renewables
- Battery Energy Storage System
- Power
- Hazardous Waste
- .....
- Transport
- Marine
- Airports
- Rail
- .....
- Healthcare
- Medical
- Laboratories
- Pharmaceuticals
- Secure Storage
- .....
- High Security
- ATM
- Banking
- Cash Handling
- Safe Deposit Centres
- Prisons
- Residential
- Police
- Armouries
- Military
- Gun Storage
- .....
- Education
- Schools
- Communal
- .....
- Architecture
- Construction
- .....
- Arts and Museums



*Burton Security's core principle is to ensure products are tested to the highest standards. We are proud to have tested products to LPCB standards and feature in Red Book Live.*

## DESIGN & INNOVATION THE SURE DEFENCE TEAM

We are proud to manufacture our Embassy modular steel security walling and safe room products here in the UK. Our growth is through design, innovation and investment in British engineering.

Each project is managed and designed in house meaning we can offer a full turnkey security solution starting with a dedicated security team of experts who will discuss your requirements and start putting your concept plans into a working design.

Our design team will then create CAD drawings to match your space and the security protection level required, followed with a quotation which will be prepared for you to review.

Once the security design project has been agreed you will be introduced to a dedicated project manager who will oversee the whole production and installation process, starting with the all-important on-site survey.

Your bespoke Embassy walling or room will then go into production at our own fabrication workshops, ready for our skilled and fully vetted safe & vault installation engineers to install on site.



ATM Rooms and Banking



Safe Deposit Centres  
Cash Handling



Critical National infrastructure  
Nuclear



Pharmaceutical  
Laboratories  
Healthcare

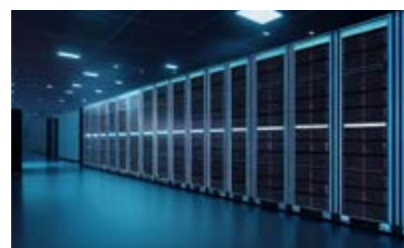

Data Centres

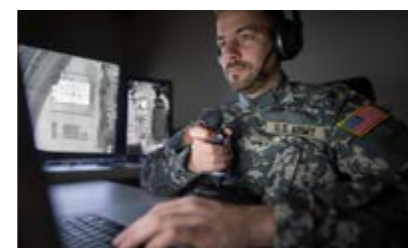

Military  
Gun Storage

### Police Preferred Specification

Proud to feature 100's of Secured by Design (SBD) official police security products that work to improve the security of buildings and their immediate surroundings to provide safe places to live, work, shop and visit.

### Burton Security - On Every Street

We have served the Banking, ATM, Safe Deposit, Vault and Large Retail Stores for over 30 Years!

### Award-winning Security Team

We have won numerous security industry award for fire and physical security designs.





# ORTHRUS Strongrooms

**LPS1175: Issue 8 F10 (SR6) and G5 Certified Room**

## Protecting People And Valuables



LPS1175: Issue 8  
Cert No: 1000 k



A free-standing high security solution of modular construction, Orthrus delivers optimum price/performance ratio. It is certified to the very latest LPS standard – LPS1175: Issue 8 and has achieved security rating F10 (SR6) G5. Each room is built to order according to the individual size and security requirements of the client. The flexibility of design and build allow this to be the perfect solution in the commercial world for high value items or indeed military/government use for sensitive materials or meeting spaces.

- Free-standing high security safe room
- Modular construction to create bespoke rooms built to your specification
- Orthrus rooms Independently tested and certified to LPS1175 (Issue 8) F10 (SR6) G5
- Built to a Police Preferred Specification -Secured by Design
- Ideal solution for creating a secure space within an existing structure
- Ideal for commercial, military and government use
- Exceeds requirements of the UK Environment Agency for the storage of radioactive source material/equipment
- Panel widths range from 150mm to 1500mm
- Rooms can be 5 or 6 sided
- Design, consultancy service and installation provided by Burton Safes
- The door and locking system can be connected to client's own alarm system and access control system
- A 2nd or 3rd lock can be added to your vault door if required
- Lock features 4 manager codes, 36 user codes, time delay and time windows, dual user functions and audit trails
- Optional emergency door, access hatch, pass through door is available

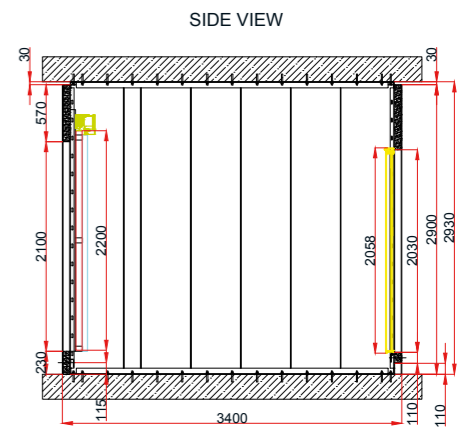

### Locking Options



Dual Locking

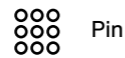

Pin



Dial

### FRONT VIEW

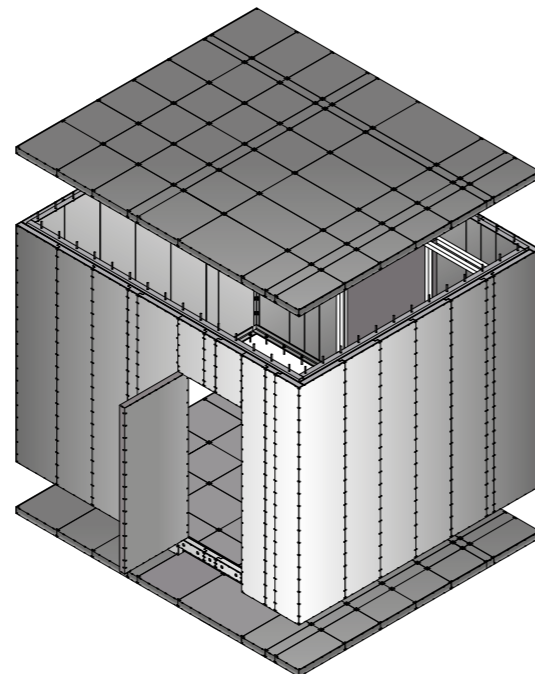
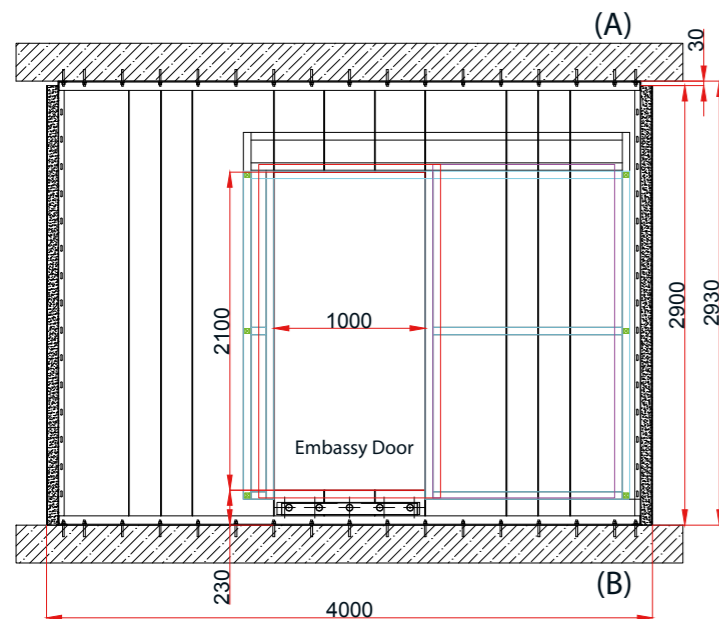

### Vault panel information

Model	Min-Max Length*	Min-Max Width	Thickness	Weight p/m2
Orthrus	1950 - 3950 (wall) 2900 (ceiling)	150 - 1500	27	105kg

### Vault door information

Model	Clear Opening Height	Clear Opening Width	Thickness	Weight p/m2
Standard Size	1960	910	160	900
Certified Range	1810 - 3950	510 - 1950	160	900
Emergency Door (in wall panels)	510	1068	160	450

\*without additional steel supports



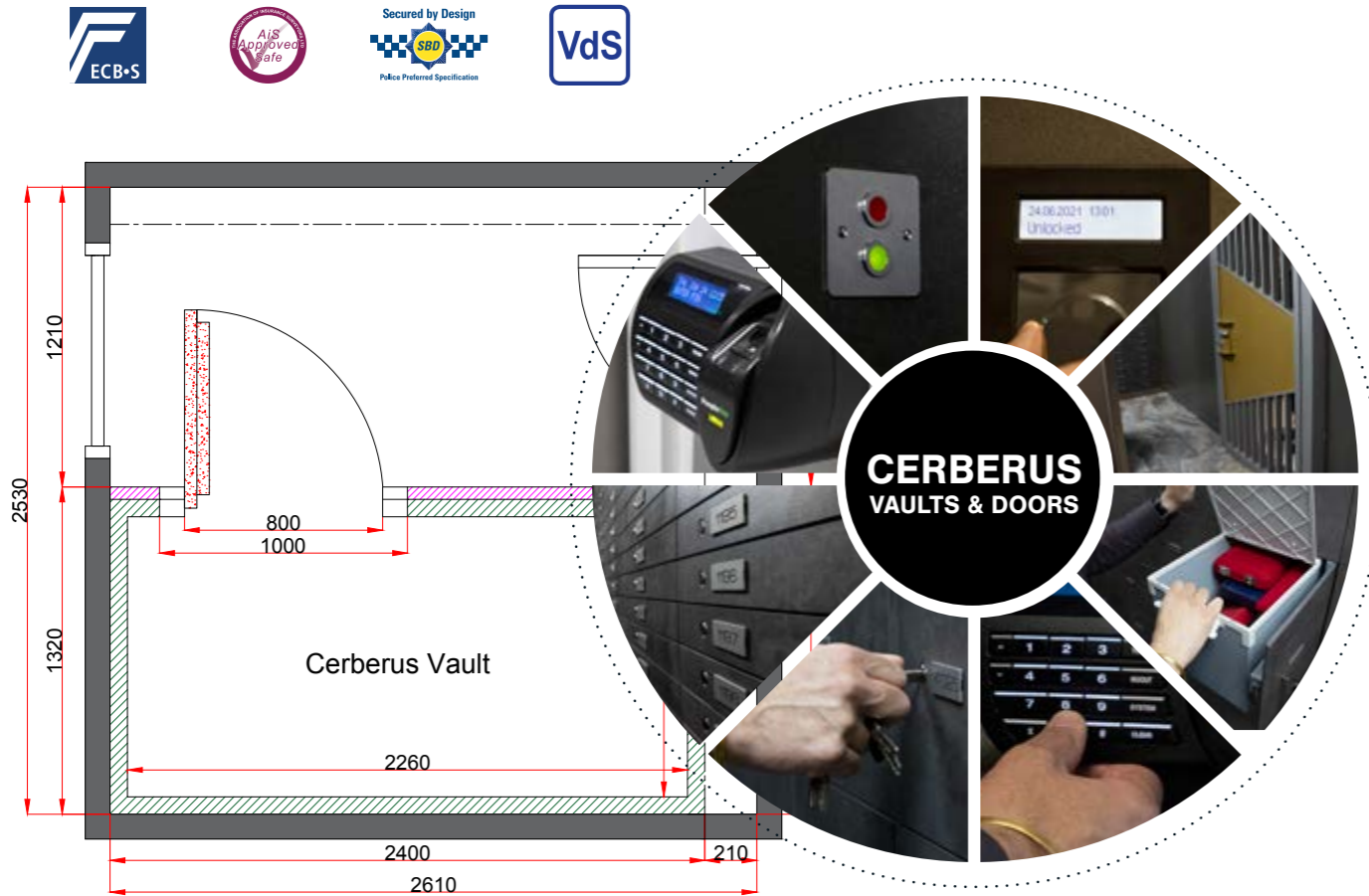

Our Vaults are unrivalled in its success, due to the modular nature of its design, and the scalable levels of security.

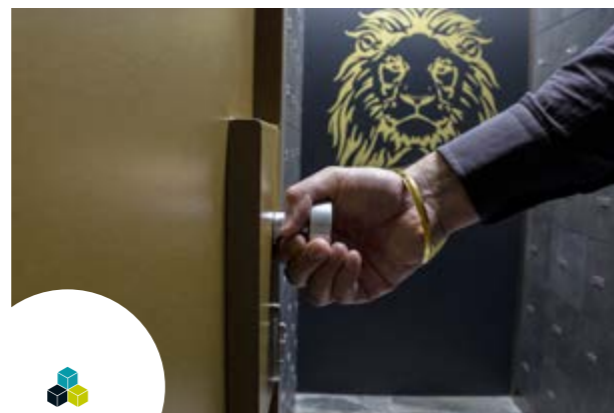
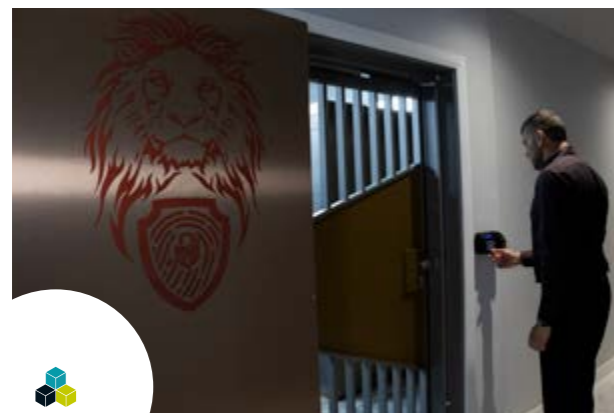

- Independently tested and certified to EN1143-1 Grades 1 - 13
- Grades 6 - 13 have been tested and certified to EX, providing additional protection against explosives
- Grades 8 - 13 have been tested and certified to CD, providing special protection against core drills
- Insurance approved by the AiS
- Built to a Police Preferred Specification - Secured by Design
- Designed to suit your size and security requirements
- Panels can be provided in lengths of up to 3600mm and can be fitted with cable and ventilation holes if required
- Mounting plates for seismic detectors can be added to your vault
- Steel cladding for the exterior is available on request
- Burton Safes offer a full consultation, design and building service. Upon completion the room is inspected and registered with VDS
- All Cerberus doors come with 2 locks as standard and a third can be ordered on request. The locks are located on the outside only

- Cerberus doors can be supplied with key, mechanical combination or electronic locks
- Electronic locks can offer redundant systems, dual user, time delay, time lock, duress alarms, audit trails, one time codes, remote programming and tiered access rights
- All doors can only open outwards and can open 180°
- An emergency door can be integrated into the main vault door or installed as a separate door\*
- A day gate can be fitted to the main vault door on request and comes with a single key lock and a second key or electric strike
- Exit handles and hydraulic closers can be added on request

**Locking Options**

\*Integrated door in door only available on Grades 1-3



Vault Model	Grade (EN1143-1)	Wall Thickness	Weight p/m2	Standard Door Aperture	Weight of Standard Door
Cerberus 1	1	27	100kg	1960 x 910	790kg
Cerberus 2 / Orthrus	2	27	105kg	1960 x 910	795kg
Cerberus 3	3	70	210kg	1960 x 910	823kg
Cerberus 4	4	70	210kg	1960 x 910	900kg
Cerberus 5	5	70	210kg	1960 x 910	900kg
Cerberus 6	6	70	225kg	1960 x 910	900kg
Cerberus 8	8	125	390kg	1960 x 910	1410kg
Cerberus 10	10	195	600kg	1960 x 910	2000kg
Cerberus 12	12	250	900kg	1960 x 910	2805kg
Cerberus 13	13	415	1215kg	1960 x 920	4300kg



# TRANSPORTA Strongrooms



Model	External (HxWxD)	Internal (HxWxD)	Weight	Cash Rating
SC10	2440 x 2440 x 2980	2110 x 2110 x 2560	2040kg	£4,000
SC20	2440 x 2440 x 6170	2110 x 2110 x 5660	3800kg	£4,000
SC800	2140 x 1125 x 1490	1750 x 850 x 1250	1500kg	£35,000
SC3000	2430 x 2440 x 2990	2180 x 2165 x 2560	4000kg	£35,000
SC6000	2940 x 2560 x 6320	2240 x 2200 x 5660	9000kg	£35,000



- Transportable high security container
- From the outside it looks like an ordinary container
- Ideal for the transportation of cash, weapons, explosives or sensitive confidential data
- Ideal for battery energy storage systems (BESS)
- Option to fit out the inside with internal walling, power, lighting and air conditioning
- Optional weapon racking and ammunition storage
- Optional anti ricochet
- Optional ballistic walling
- Optional GPS tracking can be added
- Optional side personnel door
- Double door access to maximise the opening space
- Ideal for events and exhibitions
- Ready made solution for fast deployment in an existing building
- SC10 and SC20 - tested and certified to SS3492 by SSF/SBSC
- SC800, SC3000 and SC6000 - tested and certified to EN1143-1 Grade 3 by SSF/SBSC

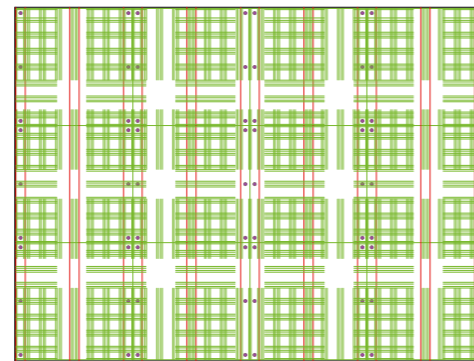
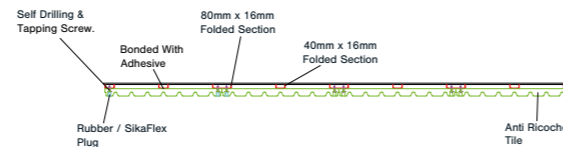

Anti ricochet matting

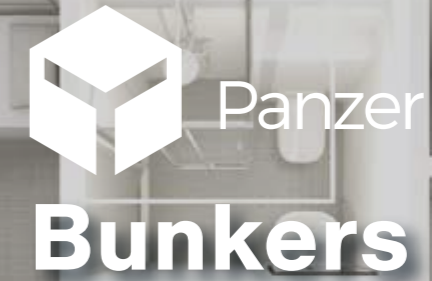

A Lifesaving Haven for People  
in Times of Crisis



## Underground Bunkers

Underground Bunkers can provide the perfect safe room solution for protecting your loved ones and possessions. We can create bunkers for installation that will protect you and your family from outside dangers. Customisable secure rooms with various access options for your needs that can be kitted out to your design. Using a high security steel walling system and security doors we can create your survival bunker room for peace of mind that your family are protected.



### Blast proof options

### Air filtration system

### Highly efficient design

### Maximum blast protection

### High-quality steel and reinforced concrete

### Additional emergency doorz







# EMBASSY RvE WINDOWS & DOORS

CERTIFIED SAFETY – BREATHTAKINGLY BEAUTIFUL



 **BURTON  
SECURITY**

 **EMBASSY**

EMBASSY MODULAR STEEL SECURITY WALLING

**THE SURE DEFENCE**

## EMBASSY RvE WINDOWS & DOORS

Certified safety – breathtakingly beautiful

We plan, produce and install PfB-certified security windows made of wood and wood-aluminium. The well-thought-out security concept sensibly coordinates fittings, glass, frames and the conditions on site. It offers secure, mechanical protection against burglary, bombardment and fire.

The Embassy RvE windows are custom-made to fit each property and fit perfectly into any architectural style: from historical, listed buildings to contemporary, modern buildings.

### THE RIGHT SOLUTION FOR EVERY ARCHITECTURE

Whether for listed buildings or for modern architecture: RvE windows are always made to measure and are functionally and aesthetically convincing.

There are hardly any limits to the shapes and formats. In collaboration with architects and builders, we develop solutions that fit perfectly into the property and meet all customer requirements.

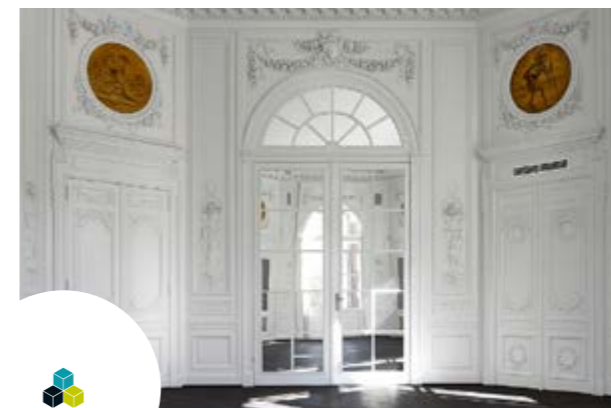

### SECURITY WINDOW TYPES FROM RvE

*Made to measure*

#### Burglary protection

Resistance classes RC2 to RC4 according to DIN EN 1627

#### Bullet resistance

Bullet resistance FB1 to FB7 according to DIN EN 1522

#### Fire protection

Resistance classes F30/T30 to F90/T90

#### Flood protection

Protection against heavy rain and flooding is becoming increasingly important worldwide. RvE therefore also builds security windows and doors that prevent unwanted water ingress.

Custom-made flood barriers then seal all building openings (windows, doors, light wells, garages, etc.). The RvE flood protection system is also suitable for listed buildings that require protection from flooding.





# Craftsmanship at its best!

## Exceptional windows + doors by RvE



- **Windows with different resistance classes**  
Resistance class RC2 to RC4
- **Bulletproof windows**  
Resistance class FB4 to FB7
- **Fire protection windows**  
Resistance class F30 to F90
- **Flood resistant windows**
- **Window with roller shutter box**  
2.5m width, infinite when coupled, up to resistance class RC3
- **Round/Oval windows**  
also with curved glass up to resistance class RC3
- **Retrofit solutions**  
up to resistance class RC3
- **Lattice window**  
up to resistance class RC3
- **Window with security button**  
instead of lockable olive
- **Windows with shutters**  
Crank or motor operated
- **Composite windows**
- **Folding and sliding systems**  
up to resistance class RC2
- **Modern windows**
- **Historical windows**
- **Monument protection window**  
up to resistance class RC3
- **Box window**  
up to resistance class RC3
- **Vertical sliding window**  
up to resistance class RC3
- **Integral window**  
up to 4.5 m high - also as a floor-to-ceiling French window
- **Post and beam facades**  
up to resistance class RC3
- **Lift and slide doors**  
up to 13m wide and 3.40 m high up to resistance class RC4 with bullet resistance FB4, barrier-free with a flat threshold
- **Special solutions/special formats**  
e.g. tilt and turn vertical sliding windows up to resistance class RC3
- **XXL formats**
- **more on request**

Good quality wood is a superb material. RvE creates something unique with it. For our windows and doors are special in every respect. Each object is manufactured made to measure: with perfection down to the last detail. As specialists for security windows and doors, we offer you effective protection with the highest quality craftsmanship. Whether for listed buildings or modern architecture: Challenge us. We create your individual solution – functional and aesthetically convincing.



# EMBASSY RvE DOORS

## Certified safety in its most beautiful form

In our factory we manufacture for you:

- Doors and portals of all shapes, sizes and styles
- From historical to modern for inside and outside
- With the most innovative technology and perfect craftsmanship

We specialize in the planning, manufacturing and assembly of security doors in resistance classes RC2 to RC4. They are certified and, upon request, equipped with bullet-resistant glass and fire protection. The RvE security doors combine high mechanical security, thermal insulation and sound insulation. Barrier-free French doors with a flat threshold are possible up to the RC3 security standard. Do you need a special solution? We would be happy to make you tailor-made suggestions for your building project.

### Burglary protection

Resistance classes RC2 to RC4 according to DIN EN 1627

DIN EN 1627 defines different resistance classes (RC = "resistance class") with regard to burglary resistance, while DIN EN numbers 1628–1630 describe the test procedures. They have replaced the pre-standard DIN V ENV 1627, which defined the resistance classes with the abbreviation "WK".

DIN EN 1627 specifies in resistance classes RC1 to RC6 how long a window must withstand an attempted break-in. They apply throughout Europe. RC1 windows & doors offer the least resistance, RC6 windows & doors offer the greatest resistance. The class shows you how long an element offers you protection in the event of a break-in.

Everything is checked, from the wall finish, glazing and locking points to professional installation.

- **RC1** low/no burglary protection, therefore not available from RvE
- **RC2** RvE elements in RC2 offer increased burglary protection: They have been proven to withstand a break-in attempt by an occasional perpetrator using simple tools such as screwdrivers, pliers and/or wedges for at least 3 minutes.
- **RC3** RvE elements in RC3 offer a high level of burglary protection: They have been proven to withstand experienced perpetrators using tools such as large crowbars or cow feet for at least 5 minutes.
- **RC4** RvE elements in RC4 offer a very high level of burglary protection: They have been proven to withstand experienced perpetrators using tools such as impact or sawing tools (axe, chisel, hammer, chisel, drill) for at least 10 minutes.
- **RC5** Upon request

### Bullet resistance

Bullet resistance FB1 to FB7 according to DIN EN 1522

To protect life and limb from firearms, we recommend equipping your windows and doors with bullet resistance in addition to the high resistance class (RC). The frame, glazing and fittings thus become the best possible security barrier without unnecessary weak points.

The glass must be of NS quality (non-shattering). Glass splinters that result from firearms can be just as deadly as the weapon itself.

Throughout Europe, the fire classes FB1 to FB7 are defined according to DIN EN 1522. These classes indicate resistance to attacks with firearms of different calibres. The fire test in German testing laboratories determines whether a window or door as a whole can withstand fire from a specific type of weapon.







# EMBASSY CBX ARMOURED SHUTTERS

PROTECT YOUR HOME  
PROTECT YOUR BUSINESS



EMBASSY MODULAR STEEL SECURITY WALLING

## THE SURE DEFENCE

# EMBASSY CBX ARMOURED SHUTTERS

Our wide range of Embassy CBX armoured shutters prevents any gap in your building or business security. You choose the security level you need and the threats you wish to control intrusion, theft, blast, weapons etc. We cover all protection levels and guarantee an elegant and unsurmountable final product.

Our products are fit for all purposes, levels of security and styles to satisfy all security needs. In addition, you can count on our own consultancy services consisting of an exhaustive study of the existing needs and structures, after which we can advise you on the product that best meets your needs.

We have a range of security shutters that offers the maximum protection against bullets, thefts, hurricanes, blasts, fires and Molotov cocktails. Without a doubt, we can provide the safest, most powerful and unsurmountable door for any location requiring maximum security, such as embassies, panic rooms or military installations.

## Protect your home

Whether the main entrance, a panic room or even a bunker; our Embassy CBX series guarantees the protection against theft attempts and unauthorised access.

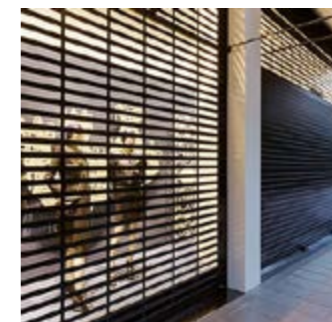

## Protect your business

The Embassy CBX system is the perfect way to protect shops, industrial warehouses or premises with special requirements. It guarantees a high protection against professional theft attempts. Perfect for offices, jewellery shops, banks, armouries or IT servers



# EMBASSY SECURBAIX RANGE

Securbaix is a security shutter manufactured from extruded aluminium that complies with the most demanding European legislation on doors, as well as including EC certification. The SECURBAIX range is the most effective way to guarantee the additional security in any type of construction. Its design, functional and elegant, facilitates its integration in any façade or interior wall and its wide range of finishings allows the customization of the chosen model.

The SECURBAIX model provides a class 3 protection (RC3) against theft attempts, thus guaranteeing a high security against robberies and intrusions. This model is ideal for constructions where an additional security is required. Its design, functional and safe, includes our E-Key Memory System and its wide range of finishings allow a complete customization depending on the specific needs of each project.

## EMBASSY SECURBAIX THERMIC

A burglary-resistant security shutter with thermal and acoustic insulation.

The SECURBAIX THERMIC model guarantees a class 3 burglar proof protection (RC3) in compliance with European standard EN 1627:2011 and is designed for its use in any kind of construction requiring additional security as well as thermal and/or acoustic insulation.

## EMBASSY SECURBAIX BL

Burglar-proof and wind-resistant security shutter.

The SECURBAIX BL model offers maximum burglar proof security and is certified to class 4 (RC4) in compliance with regulation EN 1627:2011. It is an elegant, secure and functional door with unrivalled performance for your security. Appropriate for jewellery stores, banks, museums and strategic buildings.

## EMBASSY SECURBAIX BL VISION

The only security shutter that allows you to display what's inside.

The SECURBAIX BL VISION is a high-security shutter that guarantees a class 4 (RC4) protection against theft attempts (EN 1627:2011). It perfectly combines protection and security with luminosity and transparency.

## EMBASSY SECURBAIX BL VISION XL

Burglary-resistant security roll-up door with XL die-cuts.

Designed to maximize brightness and transparency with maximum security against burglary, the SECURBAIX BL VISION XL is an elegant, functional and secure door, with class 4 burglary certification. Its die-cut slats are made from premium alloy extruded aluminium and the 400mm die-cut slat design adds visibility. Includes stainless steel side caps and integrated bearings on the side of the plinth, which provide smoother operation.

## EMBASSY DIAMOND SERIES

We shield your peace of mind.

When talking about high security, it is important to know what systems are necessary and what options exist when shielding our peace of mind. CBX systems may combine with different types and levels of protection. Sometimes the use of a burglar-proof door is necessary, but we may also require bulletproof, blast-proof or fire-resistant capabilities and often need all these options combined in one door. This is why we offer the possibility of creating a customized model that responds to your specific needs, based on a series of available options. You will receive an unsurmountable door that perfectly adapts to the structure of any location.

## EMBASSY DIAMOND BL

Burglar-proof, bulletproof and wind-resistant security shutter.

The DIAMOND BL door offers an FB4-S bulletproof protection (according to EN 1522:1999), an RC5 burglary resistance (according to EN 1627:2011), and a class 5 wind resistance (up to 1,000 Pa according to EN 12424:2000). Therefore, it offers high security against intrusions, strong winds and armed attacks. Elegant, secure and functional, this door offers the maximum performance for your peace of mind. The size of its slats facilitates the installation of this model in small spaces without losing its bulletproof capacity and being able to endure the impact of a 44-calibre firearm. It is not only one of the most secure doors in the world, but thanks to our wide range of finishings you can customize it the way you prefer to integrate the door in any kind of environment or decorative style (housing, business, industry, etc.). As an option, we can also provide our crystal silver finishing (a special anti-Molotov cocktail layer).

## EMBASSY DIAMOND BL X-TREME

RC6 burglary resistance and FB6-NS bulletproof resistance security shutter.

This model masterfully combines technology and engineering through the use of highly resistant materials such as aluminium, titanium or carbon, creating one of the safest and most unsurmountable doors in the world. Adaptable to any location (bunkers, strategic buildings, materials reserves, etc.). Manufactured with straight high resistance aluminium slats with double wall and inferior plinth reinforced with a double wall, shielded slides and anti-friction nylon.

## EMBASSY DIAMOND BL X-TREME BLAST

Security shutter that offers the maximum protection against bullets, thefts, blasts and Molotov cocktails.

Our DIAMOND BL X-TREME BLAST model has been tested and can resist explosions of up to 20 kg of TNT situated 4 metres away, in accordance with its EXR5-NS classification (in compliance with regulation UNE-EN 13123-2:2004). It also provides an FB6-NS bulletproof protection (EN 1522), RC6 burglary resistance (EN 1628) and class 5 wind resistance in compliance with UNE-EN 12424:2000).

## EMBASSY DIAMOND BL X-TREME MAX

Security shutter that offers the maximum protection against bullets, thefts, hurricanes, blasts, fires and Molotov cocktails

The DIAMOND BL X-TREME MAX model is our most powerful and complete version within the DIAMOND series, including the certifications to the most demanding European regulations. It has the capacity to resist powerful electrical cutting tools, explosions of up to 20kg of TNT 4 metres away, heavy munition such as the AK47, fires for up to 60 minutes, winds of more than 300 km/h and 20 Molotov cocktail impacts. Without a doubt, it is the safest, most powerful and unsurmountable door for any location requiring maximum security, such as embassies, panic rooms or military installations.

# DIAMOND BL X-TREME BLAST

We manufacture with top quality materials to offer our clients the best guarantee.

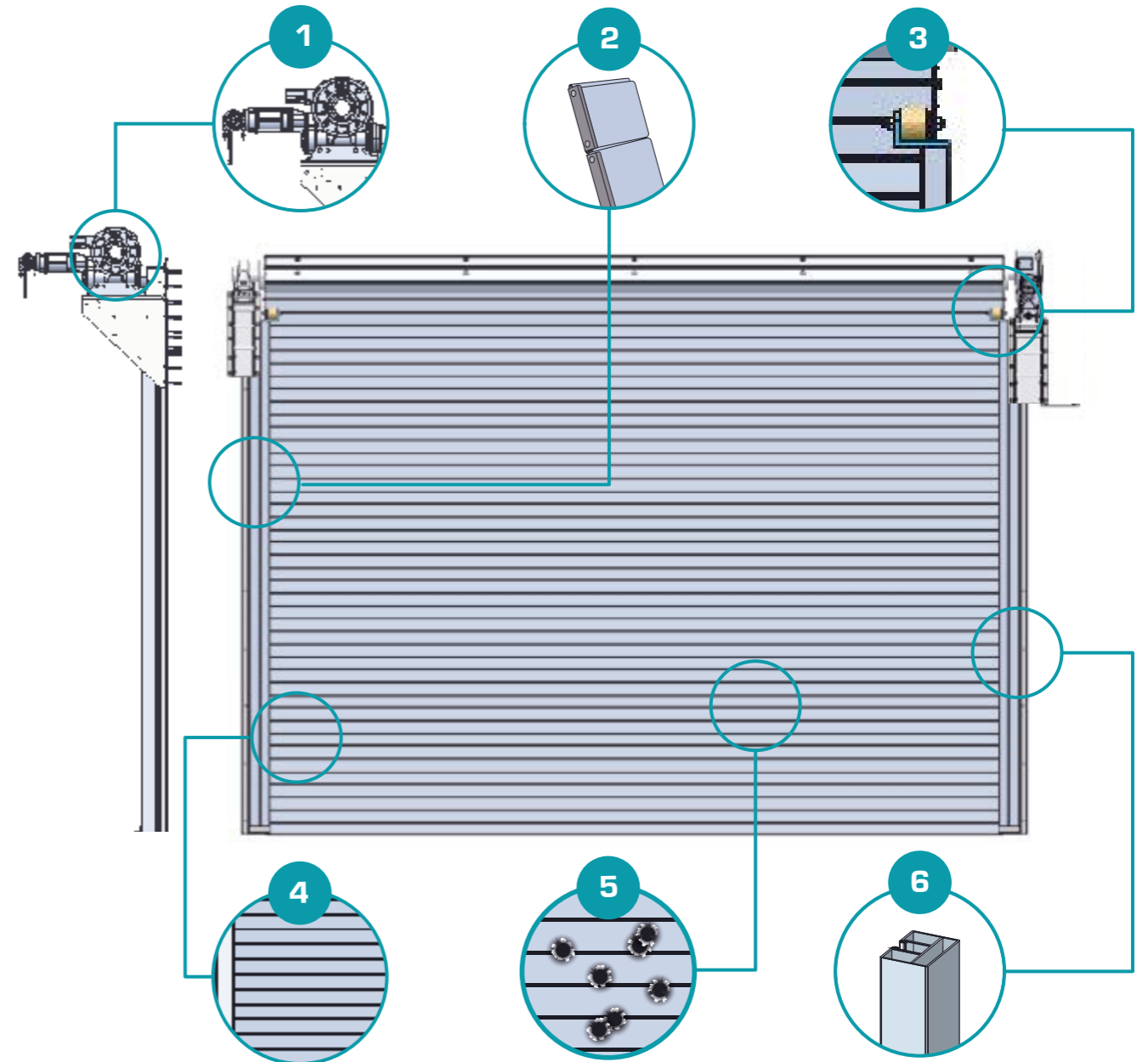

### 1 ENGINES

We provide high-capacity and high-quality engines, of up to 5,000 Nm of power, ready for any type of international voltage.

### 3 ANTI-WEAR / ANTI-FATIGUE SHIELDED BEARINGS

Exclusive system with shielded bearings of 10 Tn, making the shutter work properly and always guiding it without fatigues or distortions.

### 5 BULLETPROOF AND BURGLAR-PROOF SYSTEM

Our exclusive profiles support projectiles of 7.62 x 51 mm, FB6-NS (AK 47 - Kalashnikov), and burglary attempts of RC6 class (maximum burglary/terrorist resistance on international level).

### 2 SYSTEM OF EXCLUSIVE STAINLESS STEEL CAPS

They do not break or rust, avoiding the profiles of the shutter to pop out laterally, causing expensive failures (exclusive of CBX).

### 4 ANTI MOLOTOV COCKTAIL FINISHING

This exclusive CBX system repels Molotov cocktails through a special treatment applied to the shutter that repels fire and prevents the Molotov cocktail from adhering.

### 6 REINFORCED PROFILES

CBX manufactures all its shutters in an extruded aluminium alloy of high-resistance that allows sizes of up to 7,000 (width) x 5,500 (height) mm, and 5 Tn of weight.





**IF IT MATTERS TO YOU,  
SECURE IT WITH US...**



 **BURTON**  
***SECURITY***

[www.burtonsafes.co.uk](http://www.burtonsafes.co.uk) | +44 (0) 1484 663388 | [enquiries@burtonsecurity.com](mailto:enquiries@burtonsecurity.com)

Brockholes Business Park, Rock Mill Road, Holmfirth, HD9 7BN